

# Flygt 3202.090/180



---

# Table of Contents

<b>1 Introduction.....</b>	<b>2</b>
1.1 Specially approved products.....	2
<b>2 Product Description.....</b>	<b>3</b>
2.1 The data plate.....	3
2.2 Approvals.....	4
2.3 Product denomination.....	5
<b>3 Exploded View.....</b>	<b>7</b>
3.1 Drive Unit.....	7
3.1.1 Standard and explosion-proof.....	7
3.2 Hydraulic Unit.....	8
3.2.1 N_ HT.....	8
3.2.2 N_ LT.....	9
3.2.3 N_ MT.....	10
3.3 Installation Components.....	11
3.3.1 FP/NP.....	11
3.3.2 FS/NS.....	12
3.3.3 FT/NT.....	13
3.3.4 FZ/NZ.....	14
<b>4 List of Parts.....</b>	<b>16</b>
4.1 3202.090/180.....	16

# 1 Introduction

## Purpose of this manual

The purpose of this manual is to provide necessary information on spare parts and accessories order.

## Disclaimer

Always use genuine Flygt parts. The use of other spare parts or accessories can invalidate any claims for warranty or compensation. Xylem does not take any responsibility for damages that are caused by the use of non-original parts. For more information, contact your local sales and service representative.

## Data for ordering spare parts

The following information is needed for spare part orders:

- Serial number of the product
- Part number
- Quantity of bulk material, see \* in tables

## 1.1 Specially approved products

### Qualification of personnel

Only Xylem or Xylem-authorized service personnel may undertake repair work on specially approved products.

### Dimensional accuracy inspection

Spare parts marked with (Ex) after the part number are subject to dimensional accuracy inspection when used in specially approved products.

# 2 Product Description

## 2.1 The data plate

The data plate is a metal label that is located on the main body of the products. The data plate lists key product specifications. Specially approved products also have an approval plate.

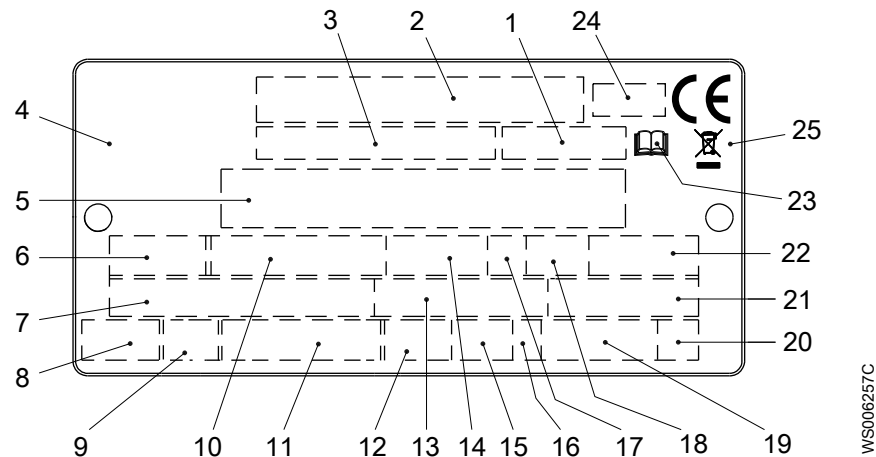



1. Curve code or Propeller code
2. Serial number
3. Product number
4. Country of origin
5. Additional information
6. Phase; type of current; frequency
7. Rated voltage
8. Thermal protection
9. Thermal class
10. Rated shaft power
11. International standard
12. Degree of protection
13. Rated current
14. Rated speed
15. Maximum submergence
16. Direction of rotation: L=left, R=right
17. Duty class
18. Duty factor
19. Product weight
20. Locked rotor code letter
21. Power factor
22. Maximum ambient temperature
23. Read installation manual
24. Notified body, only for EN-approved Ex products
25. WEEE-Directive symbol

Figure 1: The data plate

## 2.2 Approvals

### Product approvals for hazardous locations

Pump	Approval
<ul style="list-style-type: none"> <li>• 3202.090</li> </ul>	European Norm (EN) <ul style="list-style-type: none"> <li>• ATEX Directive</li> <li>• EN 60079-0:2012/A11:2013, EN 60079-1:2014, EN ISO 80079-36:2016, EN ISO 80079-37:2016</li> <li>•  II 2 G Ex db h IIB T3 Gb</li> <li>•  I M2 Ex db h I Mb</li> </ul>
	IEC <ul style="list-style-type: none"> <li>• IECEx scheme</li> <li>• IEC 60079-0:2011, IEC 60079-1:2014; IEC 80079-36:2016; IEC 80079-37:2016</li> <li>• Ex db h IIB T3 Gb</li> <li>• Ex db h I Mb</li> </ul>
	FM (FM Approvals) <ul style="list-style-type: none"> <li>• Explosion proof for use in Class I, Div. 1, Group C and D</li> <li>• Dust ignition proof for use in Class II, Div. 1, Group E, F and G</li> <li>• Suitable for use in Class III, Div. 1, Hazardous Locations</li> </ul>
	CSA Ex <ul style="list-style-type: none"> <li>• Explosion proof for use in Class I, Div. 1, Group C and D</li> </ul>

#### EN approval plate

This illustration describes the EN approval plate and the information that is contained in its fields.

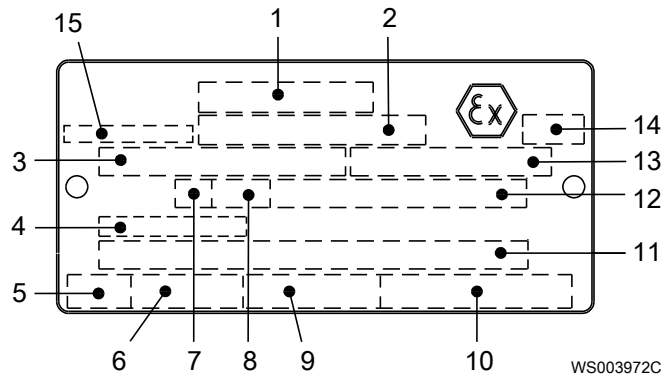

1. Approval
2. Approval authority and Approval number
3. Approved drive unit
4. Cable entry temperature
5. Stall time
6. Starting current or Rated current
7. Duty class
8. Duty factor
9. Input power
10. Rated speed
11. Additional information
12. Maximum ambient temperature
13. Serial number
14. ATEX marking
15. Country of origin

#### IEC approval plate

This illustration describes the IEC approval plate and the information that is contained in its fields.

International Norm; not for EU member countries.

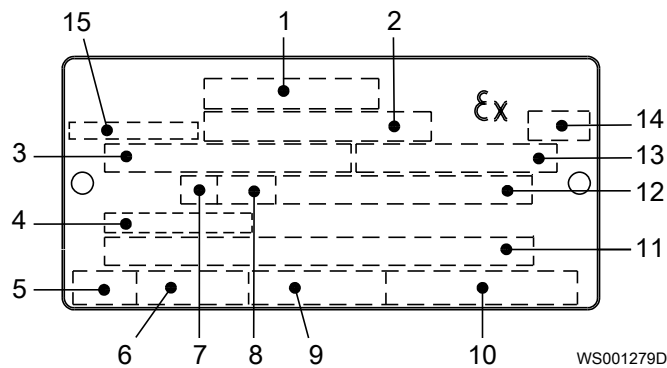

1. Approval
2. Approval authority and Approval number
3. Approved drive unit
4. Cable entry temperature
5. Stall time
6. Starting current or Rated current
7. Duty class
8. Duty factor
9. Input power
10. Rated speed
11. Additional information
12. Maximum ambient temperature
13. Serial number
14. ATEX marking
15. Country of origin

### FM approval plate

This illustration describes the FM approval plate and the information that is contained in its fields.

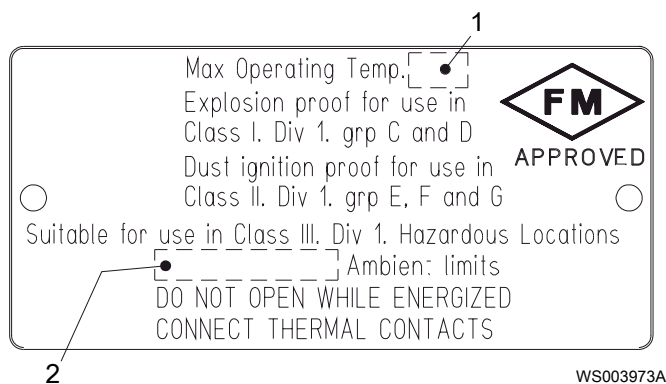

1. Temperature class
2. Maximum ambient temperature

### CSA approval plate

This illustration describes the CSA approval plate and the information that is contained in its fields.

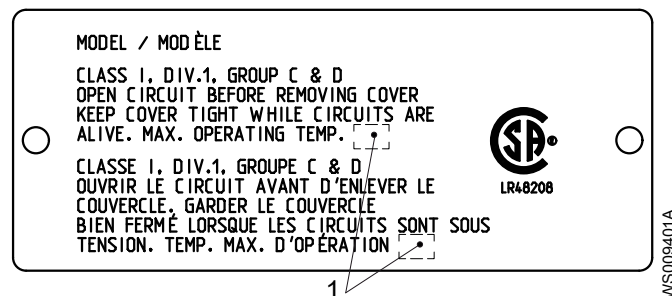

1. Temperature class

## 2.3 Product denomination

### Reading instruction

In this section, code characters are illustrated accordingly:

X = letter

Y = digit

The different types of codes are marked up with a, b and c. Code parameters are marked up with numbers.

Codes and parameters

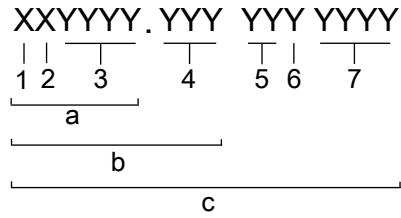

WS006265B

Type of Callout	Number	Indication
Type of code	a	Sales denomination
	b	Product code
	c	Serial number
Parameter	1	Hydraulic end
	2	Type of installation
	3	Sales code
	4	Version
	5	Production year
	6	Production cycle
	7	Running number





## 3.2 Hydraulic Unit

### 3.2.1 N\_HT

Curve: 450, 452, 454, 456, 458, 460, 462, 465 – 469

N\_ 3202 HT

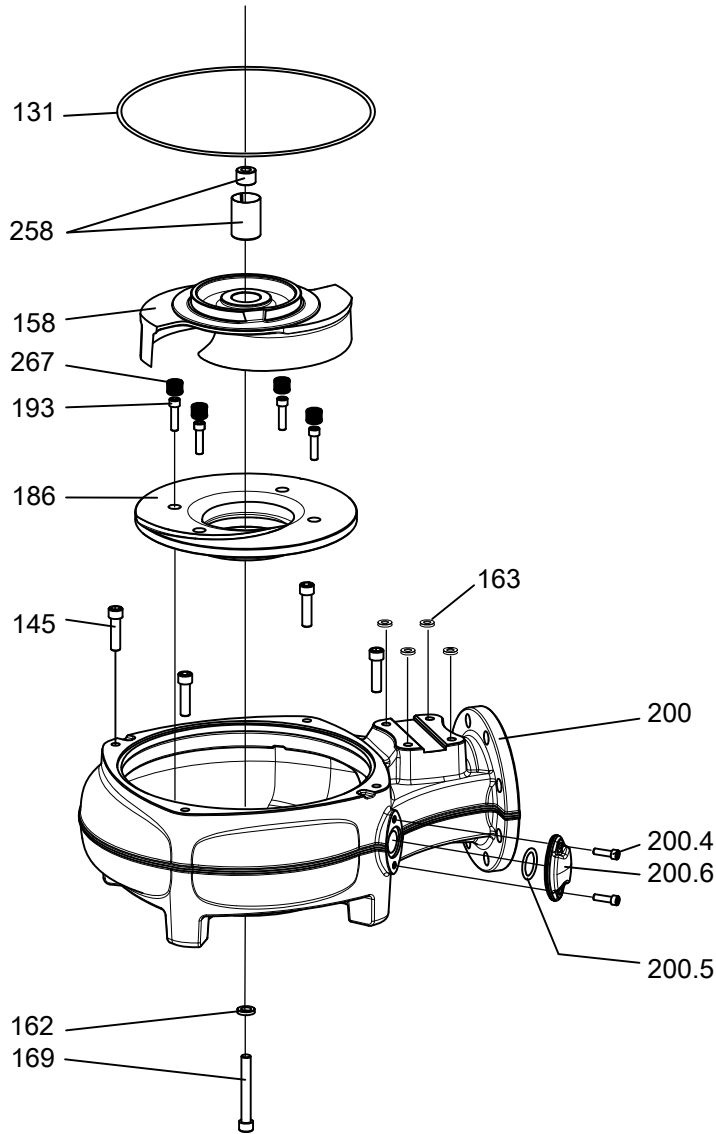

31326

## 3.2.2 N\_LT

Curve: 610, 612, 614 – 619

## N\_3202 LT

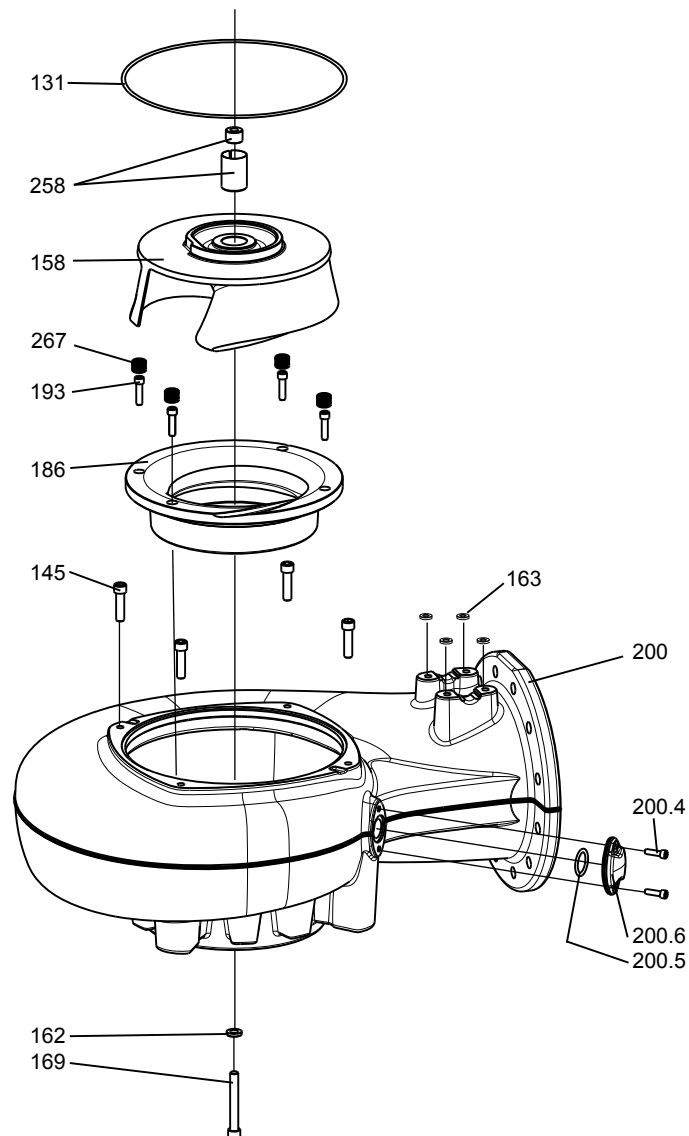

31330

### 3.2.3 N\_MT

Curve: 431 – 435, 640 – 643

### N\_3202 MT

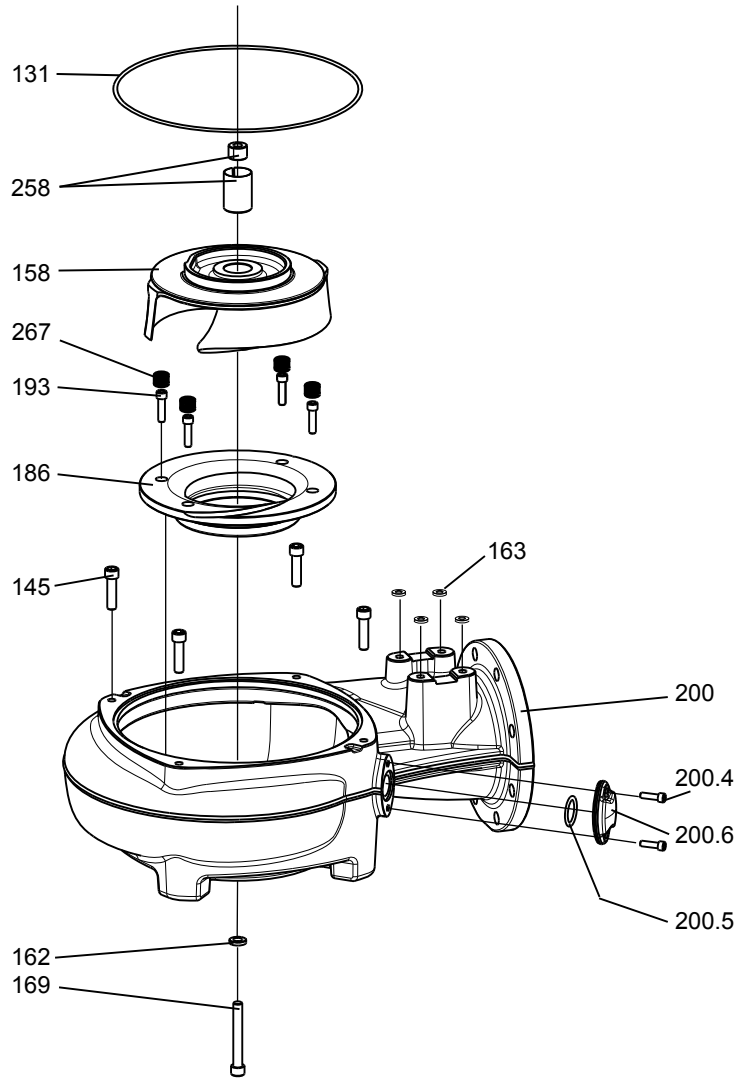

31328

## 3.3 Installation Components

### 3.3.1 FP/NP FP/NP 3202

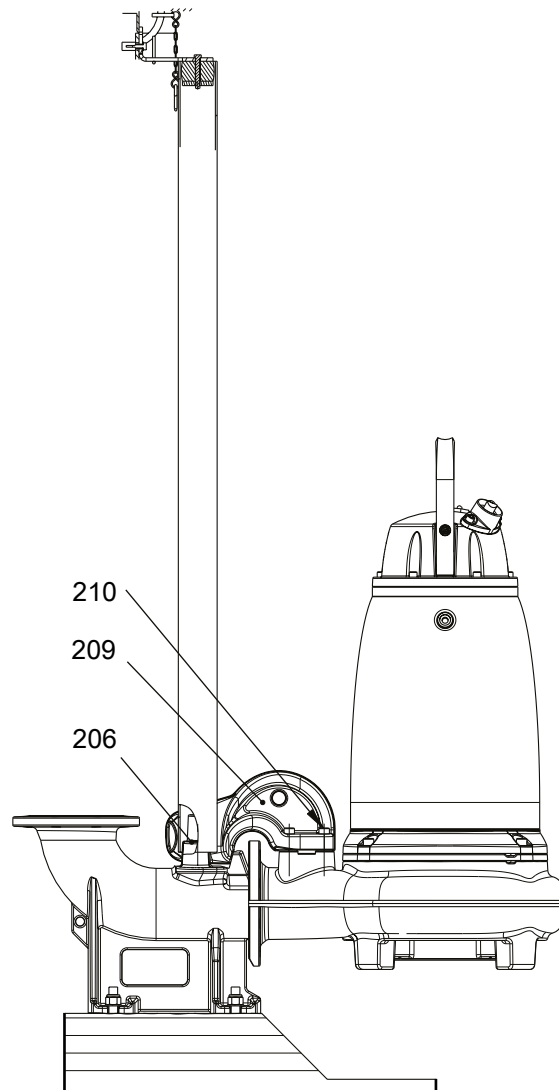

31083

### 3.3.2 FS/NS

FS, NS 3202

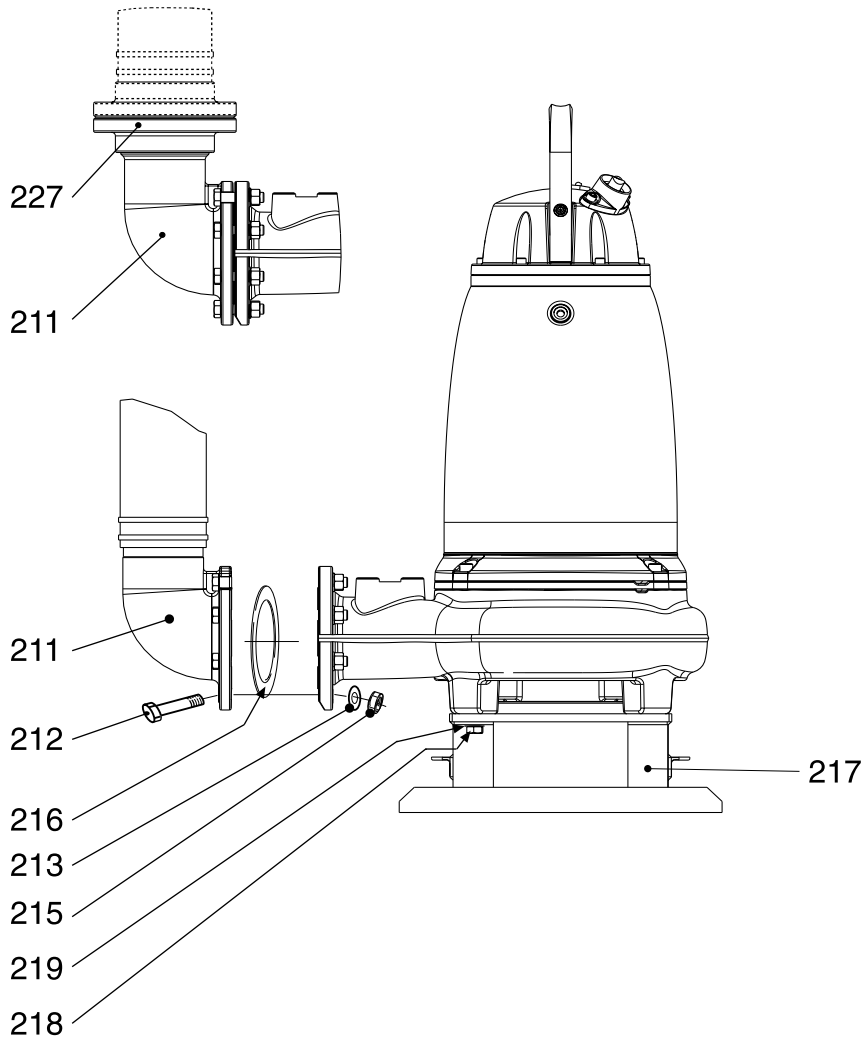

31084

3.3.3 FT/NT

FT/NT 3202

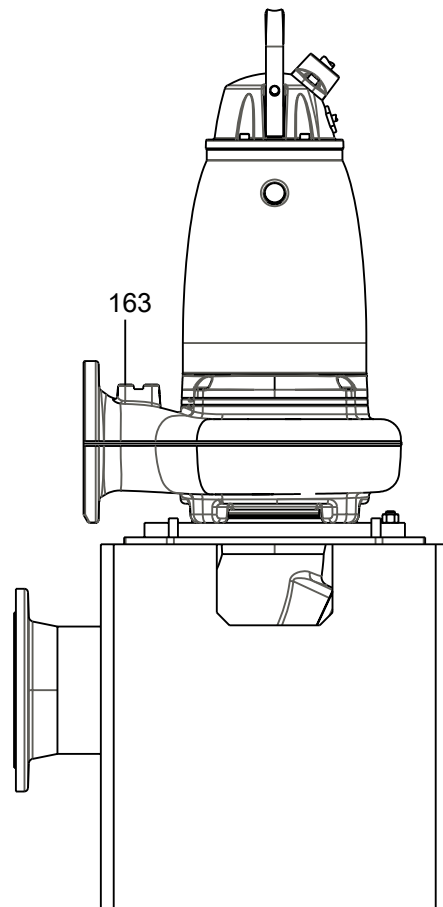

31488

### 3.3.4 FZ/NZ

Standard design

FZ/NZ 3202

Alt. 1

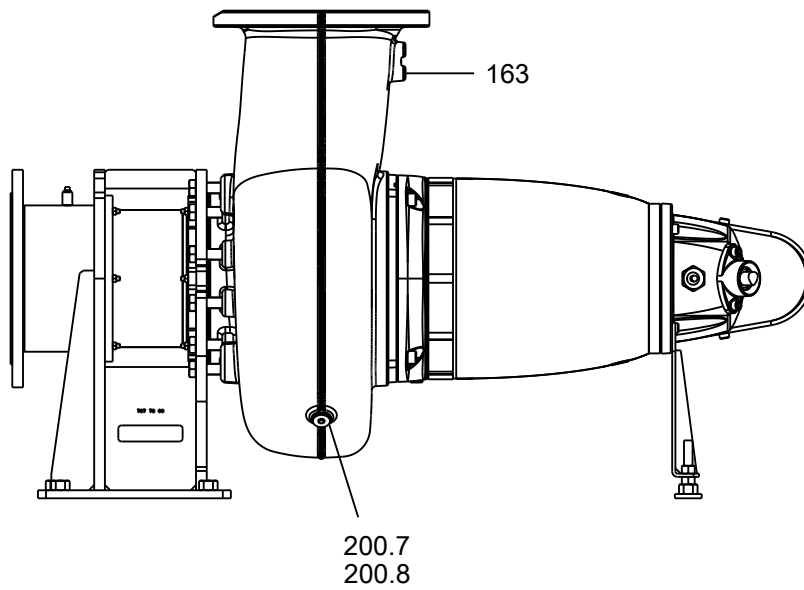

31494



Alternative design, with service cart

FZ/NZ 3202

Alt. 2

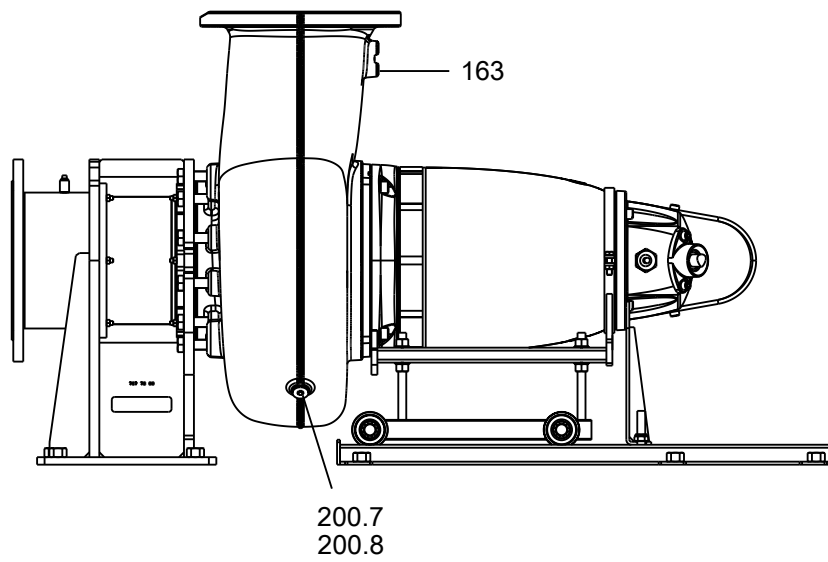

31495

For more information, refer to Mechanical Installation Equipment on TPI.

# 4 List of Parts

## 4.1 3202.090/180

Pos. No	Part. No	Type	Denomination	Qty/Version	
				090	180
1	607 78 00	(Ex)	Lifting handle	1	1
2	83 04 53		Hex.socket hd screw M12X45-A4-80	2	2
7	83 45 52		Cable tie 292X3.5 MM	1	1
7	83 45 59		Cable tie 200X2.4 PA 6/6-55+105	1	1
8	630 68 00	(Ex)	Data plate USE 6306801 AS SPARE PART	2	2
8	630 69 00	(Ex)	Certificate plate EN	2	
8	630 70 00	(Ex)	Certificate plate FM	2	
8	630 69 01	(Ex)	Certificate plate IECEX	2	
8	801 03 02		Name plate	1	
8	630 76 00		Plate HOT WATER PRODUCT		1
9	773 29 00		Connection plate	1	1
9	83 93 50		Marking strip 5-GW (T1, T2, T15, T16)	1	1
9	832 94 00		Connection plate	1	1
9	81 65 46		Marking plate 55 GW (FUNCTIONAL GROUND)	1	1
9	681 58 00		Sticker SENSOR CONNECTED T1-T2	2	2
9	83 93 51		Marking strip W5,V5,U5,V2,W1,U2,V1,W2,U	1	1
10	82 20 88		Drive screw 4X5-A2/A4	8	8
11	82 00 11		Hex.socket hd screw M6X12-A2-70	2	
13	642 16 00	(Ex)	Earthing plate	1	1
14	94 19 22		Control cable subcab 7X1,5	*	*
14	94 19 20		Control cable subcab 12X1.5 MM2 OD=18.2-21.2MM	*	*
15	397 81 00	(Ex)	Gland screw Pr 37	1	1
23	94 20 60		Motor cable subcab 4G4+2X1.5	*	*
23	94 20 56		Motor cable subcab 4G6+2X1.5	*	*
23	94 19 81		Motor cable subcab 4G10+S(2X0.5)	*	*
23	94 19 82		Motor cable subcab 4G16+S(2X0.5)	*	*
23	94 19 83		Motor cable subcab 4G25+S(2X0.5)	*	*
23	94 19 84		Motor cable subcab 4G35+S(2X0.5)	*	*
23	94 20 82		Motor cable subcab 7G2.5+2X1.5	*	*

Pos. No	Part. No	Type	Denomination	Qty/Version	
				090	180
23	94 20 80		Motor cable subcab 7G4+2X1.5	*	*
23	94 19 80		Motor cable subcab 7G6+S(2X0.5)	*	*
23	94 19 85		Motor cable subcab 3X50+2G35/2+S(2X0.5)	*	*
23	94 19 91		Motor cable subcab S3X6+3X6/3+S(4X0.5)	*	*
23	94 19 92		Motor cable subcab S3X10+3X10/3+S(4X0.5)	*	*
23	94 19 93		Motor cable subcab S3X16+3X16/3+S(4X0.5)	*	*
23	94 19 94		Motor cable subcab S3X25+3X16/3+S(4X0.5)	*	*
23	94 19 95		Motor cable subcab S3X35+3X16/3+S(4X0.5)	*	*
24	642 17 01	(Ex)	Entrance flange (14)-32 MM	1	
24	642 17 01	(Ex)	Entrance flange (14)-32 MM	2	
24	597 87 01	(Ex)	Entrance flange ISO G1 1/4, (17)-23 MM	1	1
24	597 87 01	(Ex)	Entrance flange ISO G1 1/4, (17)-23 MM	2	2
24	597 87 04	(Ex)	Entrance flange ISO 228/1-G2, (17)-23 MM	1	1
24	597 87 04	(Ex)	Entrance flange ISO 228/1-G2, (17)-23 MM	2	2
24	597 87 11	(Ex)	Entrance flange 1 1/2-11.5 NPT, (17)-23 M	1	1
24	597 87 11	(Ex)	Entrance flange 1 1/2-11.5 NPT, (17)-23 M	2	2
24	597 87 08	(Ex)	Entrance flange 2-11.5 NPT, (17)-23 MM	1	1
24	597 87 08	(Ex)	Entrance flange 2-11.5 NPT, (17)-23 MM	2	2
24	642 17 00		Entrance flange (20)-32 MM		1
24	642 17 00		Entrance flange (20)-32 MM		2
26	83 04 53		Hex.socket hd screw M12X45- A4-80	2	2
26	83 04 53		Hex.socket hd screw M12X45- A4-80	4	4
31	82 74 63		O-ring 49.5X3 NBR	1	1
31	82 74 63		O-ring 49.5X3 NBR	2	2
31	82 81 03		O-ring 49.5X3 FPM	1	1
31	82 81 03		O-ring 49.5X3 FPM	2	2
32	799 31 01	(Ex)	Entrance cover	1	
			For motor cable		
32	799 31 03	(Ex)	Entrance cover	1	
			For motor cable x2		
32	799 31 05	(Ex)	Entrance cover	1	
			For auxiliary cable For motor cable		
32	799 31 07	(Ex)	Entrance cover	1	
			For auxiliary cable For motor cable x2		
32	799 31 00		Entrance cover		1
			For motor cable		
32	799 31 02		Entrance cover		1
			For motor cable x2		

Pos. No	Part. No	Type	Denomination	Qty/Version			
				090	180		
32	799 31 04		Entrance cover	For auxiliary cable	For motor cable		1
32	799 31 06		Entrance cover	For auxiliary cable	For motor cable x2		1
33	82 74 98		O-ring 249.3X5.7 NBR			1	1
33	82 80 87		O-ring 249.3X5.7 FPM			1	1
35	83 04 53		Hex.socket hd screw M12X45-A4-80			6	6
45	82 00 11		Hex.socket hd screw M6X12-A2-70			2	2
45	83 02 79		Hex.socket hd screw M6X25-A4-70			2	2
45	82 00 17		Hex.socket hd screw M6X25-A2-70			2	2
46	82 35 73		Plain washer 6.4X12X1.6-A4-170HV			1	1
49	83 42 35		End sleeve 10 MM2; L=12 MM			6	6
49	83 42 48		End sleeve H16/24			3	3
49	83 42 49		End sleeve H25/30			3	3
49	83 42 50		End sleeve H35/30D			3	3
49	83 42 48		End sleeve H16/24			6	6
49	83 42 51		End sleeve H50/36			3	3
49	83 42 49		End sleeve H25/30			6	6
49	83 42 51		End sleeve H50/36			6	6
49	83 42 53		End sleeve H6/20			6	6
51	83 42 62		Closed-end splice 0.33-0.82 (AWG 22-18)			2	2
53	82 00 11		Hex.socket hd screw M6X12-A2-70			2	2
54	607 25 00		Rail 35X7.5			1	1
54	607 25 02		Rail			1	1
56	642 16 00	(Ex)	Earthing plate			1	1
58	83 07 41		Protective cap 80X10 MM NBR			1	1
60	82 56 22		Spring washer 89.5X72X0.66			1	1
61	83 30 18		Ball bearing 40X90X36.5 MM			1	1
69	607 65 01	(Ex)	Stator housing			1	
69	607 65 00		Stator housing				1
72	82 75 03		O-ring 299.3X5.7 NBR			1	1
72	82 80 88		O-ring 299.3X5.7 FPM			1	1
73	607 04 03		Shaft unit	30-19-4A		1	1
73	607 04 01		Shaft unit	30-24-4A		1	1
73	607 04 04		Shaft unit	30-29-4A		1	1
73	652 42 00	(Ex)	Shaft unit	30-18-6A		1	1
73	652 42 03		Shaft unit	30-23-6A		1	1
73	652 42 04		Shaft unit	30-29-6A		1	1

Pos. No	Part. No	Type	Denomination	Qty/Version		
				090	180	
79	647 70 01	(Ex)	Stator 30-19-4a	50 Hz 4-poles 660V-690V Y 380V-400V D P2=30kW 60 Hz 4-poles 440V-460V D P1=35KW 50 Hz 4-poles 660V-690V Y 380V-400V D Max P1=29KW 60 Hz 4-poles 440V-460V D P2=34kW/45hp	1	1
79	647 70 03	(Ex)	Stator 30-19-4a	50 Hz 4-poles 500V D P2=30kW 60 Hz 4-poles 575V-600V D P1=35KW 50 Hz 4-poles 500V D P1=29KW 60 Hz 4-poles 575V-600V D P2=34kW/45hp	1	1
79	647 70 05	(Ex)	Stator 30-19-4a	50 Hz 4-poles 415V-440V D P2=30kW 50 Hz 4-poles 415V-440V D Max P1=29KW	1	1
79	647 70 04	(Ex)	Stator 30-19-4a	60 Hz 4-poles 460V YSER 230V Y// P1=35KW 60 Hz 4-poles 460V YSER 230V Y// P2=34kW/45hp	1	1
79	647 70 07	(Ex)	Stator 30-19-4a	60 Hz 4-poles 380V D P1=35KW 60 Hz 4-poles 380V D P2=34kW/45hp	1	1
79	607 11 01	(Ex)	Stator 30-24-4a	50 Hz 4-poles 660V-690V Y 380V-400V D P2=37kW 60 Hz 4-poles 440V-460V D Max P1=44KW 50 Hz 4-poles 660V-690V Y 380V-400V D P1=36KW 60 Hz 4-poles 440V-460V D P2=45kW/60hp	1	1
79	607 11 03	(Ex)	Stator 30-24-4a	50 Hz 4-poles 500V D P2=37kW 60 Hz 4-poles 575V-600V D P1=43KW 50 Hz 4-poles 500V D P1=36KW 60 Hz 4-poles 575V-600V D P2=45kW/60hp	1	1
79	607 11 05	(Ex)	Stator 30-24-4a	50 Hz 4-poles 415V-440V D P2=37kW 50 Hz 4-poles 415V-440V D P1=36KW	1	1
79	607 11 04	(Ex)	Stator 30-24-4a	60 Hz 4-poles 460V YSER 230V Y// P1=43KW 60 Hz 4-poles 460V YSER 230V Y// P2=45kW/60hp	1	1
79	607 11 07	(Ex)	Stator 30-24-4a	60 Hz 4-poles 380V D P1=43KW 60 Hz 4-poles 380V D P2=45kW/60hp	1	1
79	647 72 01	(Ex)	Stator 30-29-4a	50 Hz 4-poles 660V-690V Y 380V-400V D P2=45kW 60 Hz 4-poles 440V-460V D P1=52KW 50 Hz 4-poles 660V-690V Y 380V-400V D P1=43KW 60 Hz 4-poles 440V-460V D P2=52kW/70hp	1	1
79	647 72 03	(Ex)	Stator 30-29-4a	50 Hz 4-poles 500V D P2=45kW 60 Hz 4-poles 575V-600V D P1=52KW 50 Hz 4-poles 500V D P1=43KW 60 Hz 4-poles 575V-600V D P2=52kW/70hp	1	1
79	647 72 05	(Ex)	Stator 30-29-4a	50 Hz 4-poles 415V-440V D P2=45kW 50 Hz 4-poles 415V-440V D P1=43KW	1	1
79	647 72 07	(Ex)	Stator 30-29-4a	60 Hz 4-poles 660V Y 380V D P1=52KW 60 Hz 4-poles 660V Y 380V D P2=52kW/70hp	1	1

Pos. No	Part. No	Type	Denomination	Qty/Version		
				090	180	
79	647 74 01	(Ex)	Stator 30-18-6a	50 Hz 6-poles 660V-690V Y 380V-400V D P2=22kW 60 Hz 6-poles 440V-480V D P1=27KW 50 Hz 6-poles 660V-690V Y 380V-400V D P1=22KW 60 Hz 6-poles 440V-480V D P2=26kW/35hp	1	1
79	647 74 03	(Ex)	Stator 30-18-6a	50 Hz 6-poles 500V D P2=22kW 60 Hz 6-poles 575V-600V D P1=27KW 50 Hz 6-poles 500V D P1=22KW 60 Hz 6-poles 575V-600V D P2=26kW/35hp	1	1
79	647 74 05	(Ex)	Stator 30-18-6a	50 Hz 6-poles 415V-440V D P2=22kW 50 Hz 6-poles 415V-440V D P1=22KW	1	1
79	647 74 04	(Ex)	Stator 30-18-6a	3-phase 60 Hz 6-poles 460V YSER 230V Y// P1=27KW 60 Hz 6-poles 460V YSER 230V Y// P2=26kW/35hp	1	1
79	647 74 07	(Ex)	Stator 30-18-6a	60 Hz 6-poles 660V Y 380V D P1=27KW 60 Hz 6-poles 660V Y 380V D P2=26kW/35hp	1	1
79	647 76 01	(Ex)	Stator 30-23-6a	50 Hz 6-poles 660V-690V Y 380V-400V D P2=30kW 60 Hz 6-poles 440V-480V D Rated power 30kW P1=33KW 50 Hz 6-poles 660V-690V Y 380V-400V D P1=28KW 60 Hz 6-poles 440V-480V D P2=34kW/45hp	1	1
79	647 76 03	(Ex)	Stator 30-23-6a	50 Hz 6-poles 500V D P2=30kW 60 Hz 6-poles 575V-600V D P1=33KW 50 Hz 6-poles 500V D P1=28KW 60 Hz 6-poles 575V-600V D P2=34kW/45hp	1	1
79	647 76 05	(Ex)	Stator 30-23-6a	50 Hz 6-poles 415V-440V D P2=30kW 50 Hz 6-poles 415V-440V D P1=28KW	1	1
79	647 76 07	(Ex)	Stator 30-23-6a	60 Hz 6-poles 380V D 660V Y P1=33KW 60 Hz 6-poles 380V D 660V Y P2=34kW/45hp	1	1
79	647 77 01	(Ex)	Stator 30-29-6a	50 Hz 6-poles 660V-690V Y 380V-400V D P2=37kW 60 Hz 6-poles 440V-460V D P1=43KW 50 Hz 6-poles 660V-690V Y 380V-400V D P1=35KW 60 Hz 6-poles 440V-460V D P2=45kW/60hp	1	1
79	647 77 03	(Ex)	Stator 30-29-6a	50 Hz 6-poles 500V D P2=37kW 60 Hz 6-poles 575V-600V D P1=43KW 50 Hz 6-poles 500V D P1=35KW 60 Hz 6-poles 575V-600V D P2=45kW/60hp	1	1
79	647 77 05	(Ex)	Stator 30-29-6a	50 Hz 6-poles 415V-440V D P2=37kW 50 Hz 6-poles 415V-440V D P1=35KW	1	1
79	647 77 07	(Ex)	Stator 30-29-6a	60 Hz 6-poles 380V D P1=43KW 60 Hz 6-poles 380V D P2=45kW/60hp	1	1

Pos. No	Part. No	Type	Denomination	Qty/Version		
				090	180	
79	605 81 05	(Ex)	Stator 30-19-4a	50 Hz 4-poles 415V-440V D P2=30kW 50 Hz 4-poles 415V-440V D Max P1=29KW		1
79	605 82 05	(Ex)	Stator 30-24-4a	50 Hz 4-poles 415V-440V D P2=37kW Thermistor 50 Hz 4-poles 415V-440V D P1=36KW Thermistor		1
79	605 83 05	(Ex)	Stator 30-29-4a	50 Hz 4-poles 415V-440V D P2=45kW Thermistor 50 Hz 4-poles 415V-440V D P1=43KW Thermistor		1
79	605 84 05	(Ex)	Stator 30-18-6a	50 Hz 6-poles 415V-440V D P2=22kW Thermistor 50 Hz 6-poles 415V-440V D P1=22KW Thermistor		1
79	605 85 05	(Ex)	Stator 30-23-6a	50 Hz 6-poles 415V-440V D P2=30kW Thermistor 50 Hz 6-poles 415V-440V D P1=28KW Thermistor		1
79	605 86 05	(Ex)	Stator 30-29-6a	50 Hz 6-poles 415V-440V D P2=37kW Thermistor 50 Hz 6-poles 415V-440V D P1=35KW Thermistor		1
82	607 95 00		Cooling jacket OUTER, STEEL	Material:Steel	1	1
82	607 95 01		Cooling jacket OUTER, STAINLESS STEEL	Material:stainless steel (ASTM 316L)	1	1
83	82 79 41		O-ring 314.5X5.7 NBR		1	1
83	82 79 42		O-ring 314.5X5.7 FPM		1	1
84	82 75 08		O-ring 399.3X5.7 NBR		1	1
84	82 80 93		O-ring 399.3X5.7 FPM		1	1
101	650 51 00		Cable unit FLS10		1	1
103	663 04 00	(Ex)	Level sensor FLS10		1	
103	791 99 00		Level sensor			1
105	607 96 01	(Ex)	Bearing holder		1	
105	607 96 00		Bearing holder			1
107	82 59 20		Retaining ring SGA 70		1	1
108	696 16 01		Supporting washer		2	2
109	83 30 24		Ball bearing 3314A-2Z/C3VT113		1	1
110	83 07 61		Retaining ring 152/3,25		1	1
120	642 13 00		Plug		1	1
122	82 76 85		O-ring 17X3 NBR		1	1
122	82 79 15		O-ring 17X3 FPM		1	1
129	607 82 00		Seal housing cover		1	1
130	82 76 66		O-ring 329.79X3.53 NBR		1	1
131	82 75 08		O-ring 399.3X5.7 NBR		1	1
131	82 80 93		O-ring 399.3X5.7 FPM		1	1
133	83 04 53		Hex.socket hd screw M12X45- A4-80		6	6
141	800 92 30		Mechanical seal	WCCR/WCCR	1	1

Pos. No	Part. No	Type	Denomination	Qty/Version		
				090	180	
141	800 92 31		Mechanical seal	WCCR/RSiC	1	1
145	83 04 58		Hex.socket hd screw M16X60-A4-80		4	4
158	651 11 04		Impeller	LT 50Hz Curve code: 610	1	1
158	651 11 15		Impeller	LT 50Hz Curve code: 612	1	1
158	651 11 24		Impeller	LT 50Hz Curve code: 614 LT 60Hz Curve code: 614	1	1
158	651 11 31		Impeller	LT 50Hz Curve code: 615 LT 60Hz Curve code: 615	1	1
158	651 11 38		Impeller	LT 50Hz Curve code: 616 LT 60Hz Curve code: 616	1	1
158	651 11 45		Impeller	LT 50Hz Curve code: 617 LT 60Hz Curve code: 617	1	1
158	651 11 51		Impeller	LT 50Hz Curve code: 618 LT 60Hz Curve code: 618	1	1
158	651 11 58		Impeller	LT 60Hz Curve code: 619 LT 60Hz Curve code: 619	1	1
158	762 58 05		Impeller	MT 50Hz Curve code: 431	1	1
158	762 58 13		Impeller	MT 50Hz Curve code: 432 MT 60Hz Curve code: 432	1	1
158	762 58 21		Impeller	MT 50Hz Curve code: 433	1	1
158	762 58 32		Impeller	MT 50Hz Curve code: 434	1	1
158	762 58 40		Impeller	MT 50Hz Curve code: 435	1	1
158	762 59 00		Impeller	MT 50Hz Curve code: 640 MT 60Hz Curve code: 640	1	1
158	762 59 11		Impeller	MT 50Hz Curve code: 641 MT 60Hz Curve code: 641	1	1
158	762 59 21		Impeller	MT 50Hz Curve code: 642 MT 60Hz Curve code: 642	1	1
158	762 59 31		Impeller	MT 50Hz Curve code: 643 MT 60Hz Curve code: 643	1	1
158	762 60 00		Impeller	HT 50Hz Curve code: 450	1	1
158	762 60 09		Impeller	HT 50Hz Curve code: 452	1	1
158	762 60 18		Impeller	HT 50Hz Curve code: 454	1	1
158	762 60 27		Impeller	HT 50Hz Curve code: 456 HT 60Hz Curve code: 456	1	1
158	762 60 35		Impeller	HT 50Hz Curve code: 458 HT 60Hz Curve code: 458	1	1
158	762 60 43		Impeller	HT 50Hz Curve code: 460 HT 60Hz Curve code: 460	1	1
158	762 60 51		Impeller	HT 60Hz Curve code: 462	1	1
158	762 61 00		Impeller	HT 60Hz Curve code: 465	1	1
158	762 61 08		Impeller	HT 60Hz Curve code: 466	1	1
158	762 61 15		Impeller	HT 60Hz Curve code: 467	1	1
158	762 61 27		Impeller	HT 60Hz Curve code: 468	1	1



Pos. No	Part. No	Type	Denomination	Qty/Version	
				090	180
158	762 61 40		Impeller HT 60Hz Curve code: 469	1	1
162	82 38 01		Plain washer 17X30X6-A4-170HV	1	1
163	82 69 41		Protective plug F11	4	4
169	83 04 60		Hex.socket hd screw M16X120-A4 80	1	1
186	704 44 00		Insert ring HT DN 100	1	1
193	83 04 53		Hex.socket hd screw M12X45-A4-80	4	4
200	704 71 00		Pump housing LT DN 300 Drilled inlet	1	1
200	704 71 01		Pump housing LT DN 300 Drilled acc. to: EN 1092-2 tab. 8	1	1
200	704 71 05		Pump housing LT DN 300 Drilled acc. to: ANSI B16.1-89; tab.5	1	1
200	704 71 07		Pump housing LT DN 300 Drilled acc. to: EN 1092-2 tab. 9	1	1
200	704 71 31		Pump housing LT DN 300 Drilled acc. to: EN 1092-2 tab. 8 Installation: Z Drainage plug	1	1
200	704 71 35		Pump housing LT DN 300 Drilled acc. to: ANSI B16.1-89; tab.5 Installation: Z Drainage plug	1	1
200	704 71 37		Pump housing LT DN 300 Drilled acc. to: EN 1092-2 tab. 9 Installation: Z Drainage plug	1	1
200	704 49 00		Pump housing MT DN 200 Drilled inlet	1	1
200	704 49 06		Pump housing MT DN 200 Drilled acc. to: EN 1092-2 tab. 8 ANSI B16.1:-89;tabl.5	1	1
200	704 49 07		Pump housing MT DN 200 Drilled acc. to: EN 1092-2 tab. 9	1	1
200	704 49 36		Pump housing MT DN 200 Drilled acc. to: ANSI B16.1:-89;tabl.5 EN 1092-2 tab. 8 Installation: Z Drainage plug	1	1
200	704 49 37		Pump housing MT DN 200 Drilled acc. to: EN 1092-2 tab. 9 Installation: Z Drainage plug	1	1
200	704 52 00		Pump housing MT DN 200 MT DN 200 Drilled inlet	1	1
200	704 52 06		Pump housing MT DN 200 Drilled acc. to: EN 1092-2 tab. 8 ANSI B16.1:-89;tabl.5	1	1
200	704 52 07		Pump housing MT DN 200 Drilled acc. to: EN 1092-2 tab. 9	1	1
200	704 52 36		Pump housing MT DN 200 Drilled acc. to: EN 1092-2 tab. 8 ANSI B16.1:-89;tabl.5 Installation: Z Drainage plug	1	1
200	704 52 37		Pump housing MT DN 200 Drilled acc. to: EN 1092-2 tab. 9 Installation: Z Drainage plug	1	1
200	704 25 00		Pump housing HT DN 150 Drilled inlet	1	1
200	704 25 06		Pump housing HT DN 150 Drilled acc. to: EN 1092-2 tab. 9 ANSI B16.1-89; tab.5	1	1
200	704 25 36		Pump housing HT DN 150 Drilled acc. to: EN 1092-2 tab. 9 ANSI B16.1-89; tab.5 Installation: Z Drainage plug	1	1
200	704 42 00		Pump housing HT DN 100 Drilled inlet	1	1
200	704 42 01		Pump housing HT DN 100 60 Hz Drilled acc. to: EN 1092-2 tab. 9	1	1
200	704 42 05		Pump housing HT DN 100 Drilled acc. to: ANSI B16.1-89; tab.5	1	1

Pos. No	Part. No	Type	Denomination	Qty/Version	
				090	180
200	704 42 31		Pump housing HT DN 100 Drilled acc. to: EN 1092-2 tab. 9 Installation: Z Drainage plug	1	1
200	704 42 35		Pump housing HT DN 100 Drilled acc. to: ANSI B16.1-89; tab.5 Installation: Z Drainage plug	1	1
209	607 38 00		Sliding bracket	1	1
210	83 04 58		Hex.socket hd screw M16X60- A4-80	4	4
211	457 68 00		Discharge connection DN300 LT DN 250	1	1
211	281 79 00		Discharge connection 8" MT DN 200	1	1
211	295 57 00		Discharge connection DN150 HT Outlet DN 150	1	1
211	309 31 00		Discharge connection DN150 HT Thread : 6-8 NPSM Outer DN 150	1	1
211	309 31 01		Discharge connection DN150 HT Thread: ISO G6 Outer Outlet DN 150	1	1
211	259 82 04		Discharge connection DN100 HT DN 100	1	1
211	259 84 05		Discharge connection 4-8 NPSM HT Thread : 4-8 NPSM Outer DN 100	1	1
211	259 84 06		Discharge connection ISO G4" HT Thread: ISO G4A Outer Outlet DN 100 HT Thread: ISO G4 Outer Quick coupling: Storz diam=133 mm Outlet DN 100	1	1
212	84 34 35		Hexagon head screw M20X90- A2-70 LT	4	4
212	84 34 34		Hexagon head screw M20X80- A2-70 MT HT	8	8
212	84 34 07		Hexagon head screw M16X60- A2-70 HT	4	4
213	82 35 26		Plain washer 21X37X3-A2-170HV MT HT	8	8
213	82 35 26		Plain washer 21X37X3-A2-170HV MT HT	16	16
213	82 35 23		Plain washer 17X30X3-A2-170HV MT HT	8	8
215	82 23 62		Hexagon nut M20-A2-70 MT HT	4	4
215	82 23 62		Hexagon nut M20-A2-70 MT HT	8	8
215	82 23 61		Hexagon nut M16-A2-70 HT	4	4
216	84 65 80		Gasket 300 PN10 LT	1	1
216	283 19 00		Gasket 8" MT	1	1
216	295 64 00		Gasket 6" HT	1	1
216	259 83 00		Gasket 4" HT	1	1
217	437 88 01		Stand compl. S/T INSTALLATION LT	1	1
217	380 92 03		Stand compl. MT	1	1
217	380 92 00		Stand compl. HT MT	1	1
218	84 34 05		Hexagon head screw M16X50- A2-70 HT MT	4	4
218	84 34 04		Hexagon head screw M16X45- A2-70 HT	4	4

Pos. No	Part. No	Type	Denomination	Qty/Version	
				090	180
219	82 35 23		Plain washer 17X30X3-A2-170HV MT LT	4	4
219	82 38 01		Plain washer 17X30X6-A4-170HV HT	4	4
227	83 19 34		Coupling part STORZ ISO G4 Quick coupling: Storz diam=133 mm 133MM	1	1
229	667 40 01		Sticker	2	2
231	93 00 77		Shrink hose ID=6.4 MM	*	*
231	93 00 78		Shrink hose ID=9.5 MM	*	*
232	83 53 58		Terminal clamp WDU6/10	3	3
232	83 53 58		Terminal clamp WDU6/10		4
233	83 53 61		Terminal clamp WDU16.1000V	6	6
233	83 53 61		Terminal clamp WDU16.1000V	8	8
233	83 53 17		Terminal clamp WDU35/IK/ZA	6	6
233	83 53 17		Terminal clamp WDU35/IK/ZA	8	8
233	83 53 62		Terminal clamp WEIDMÜLLER WDU 70N	8	8
233	83 53 17		Terminal clamp WDU35/IK/ZA	9	9
233	83 53 62		Terminal clamp WEIDMÜLLER WDU 70N	9	9
234	83 53 67		Cross connection WQV 16N/2	3	3
234	650 20 01		Cross connection WQV 10N/10	1	
234	650 20 02		Cross connection WQV 16N/10	1	1
234	83 53 67		Cross connection WQV 16N/2	4	4
234	83 53 49		Cross connection WQV 35N /2	3	3
234	650 20 03		Cross connection WQV 35N/10	1	1
234	83 53 49		Cross connection WQV 35N /2	4	4
234	83 53 63		Cross connection WQV 70N/2	4	4
235	83 53 54		End support WEW 35/2	2	2
236	83 53 50		Partition	1	1
239	800 45 00		El.lead through unit 9X + 8X Stator leads = 10 - 10 mm <sup>2</sup>	1	1
239	800 45 01		El.lead through unit 9X + 8X Stator leads = 2,50 - 6 mm <sup>2</sup>	1	1
239	800 45 03		El.lead through unit 9X + 8X Stator leads = 16 - 25 mm <sup>2</sup>	1	1
240	607 48 01	(Ex)	Spring	1	1
241	82 75 00		O-ring 269.3X5.7 NBR	1	1
241	82 81 14		O-ring 269.3X5.7 FPM	1	1
242	607 79 01	(Ex)	Adapter	1	
242	607 91 11	(Ex)	Adapter Cooling jacket	1	
242	607 79 00		Adapter		1
242	607 91 10		Adapter Cooling jacket		1
243	83 04 61		Hex.socket hd screw M12X25- A4-80	2	2
245	82 75 08		O-ring 399.3X5.7 NBR	1	1
245	82 80 93		O-ring 399.3X5.7 FPM	1	1
246	82 76 66		O-ring 329.79X3.53 NBR	1	1
247	82 81 72		O-ring 119.3X5.7 FPM	1	1

Pos. No	Part. No	Type	Denomination	Qty/Version	
				090	180
251	642 13 00		Plug	2	2
252	82 76 85		O-ring 17X3 NBR	2	2
252	82 79 15		O-ring 17X3 FPM	2	2
253	607 93 02		Cooling jacket	1	1
254	809 13 00		Flow diffuser	1	1
256	608 43 00		Wire bow	3	3
257	82 44 33		Washer 120X150X3.5 A1	1	1
258	720 16 00		Sleeve unit	1	1
264	82 40 82		Plain washer 34.5X52X2-A2-70	4	4
264	82 40 69		Plain washer 35.5X52X2-A2-70	4	4
264	82 40 71		Plain washer 39.5X52X2-A2-70	4	4
264	82 40 82		Plain washer 34.5X52X2-A2-70	8	8
264	82 40 69		Plain washer 35.5X52X2-A2-70	8	8
264	82 40 71		Plain washer 39.5X52X2-A2-70	8	8
264	82 40 81		Plain washer 32.5X52X2-A2-70	4	
264	82 40 73		Plain washer 44.5X52X2-A2-70	4	4
264	82 40 82		Plain washer 34.5X52X2-A2-70	8	4
264	82 40 73		Plain washer 44.5X52X2-A2-70	8	8
265	84 18 02		Seal sleeve (20)-23 MM NBR	2	2
265	84 18 03		Seal sleeve (23)-26 MM NBR	2	2
265	84 18 04		Seal sleeve (26)-29 MM NBR	2	2
265	84 18 06		Seal sleeve (32)-35 MM NBR	2	2
265	84 18 07		Seal sleeve (36)-38 MM NBR	2	2
265	84 18 03		Seal sleeve (23)-26 MM NBR	4	4
265	84 18 04		Seal sleeve (26)-29 MM NBR	4	4
265	84 18 06		Seal sleeve (32)-35 MM NBR	4	4
265	84 18 07		Seal sleeve (36)-38 MM NBR	4	4
265	84 18 01		Seal sleeve (17)-20 MM NBR	2	2
265	84 18 05		Seal sleeve (29)-32 MM NBR	2	2
265	84 18 08		Seal sleeve (38)-41 MM NBR	2	2
265	84 18 09		Seal sleeve (41)-43 MM NBR	2	2
265	84 18 02		Seal sleeve (20)-23 MM NBR	4	2
265	84 18 05		Seal sleeve (29)-32 MM NBR	4	4
265	84 18 08		Seal sleeve (38)-41 MM NBR	4	4
265	84 18 09		Seal sleeve (41)-43 MM NBR	4	4
266	597 98 02	(Ex)	Sleeve	1	1
266	597 98 02	(Ex)	Sleeve	2	2
266	597 98 02	(Ex)	Sleeve	2	1
269	518 89 04	(Ex)	Leakage detect.unit	1	1
270	608 31 00	(Ex)	Lock washer	1	
278	669 88 01		Vibration sensor	1	1
279	82 23 32		Hexagon nut M8-A4-70	2	2
302	691 83 00		Connector unit INTENDED FOR "MAS"	1	1

Pos. No	Part. No	Type	Denomination	Qty/Version	
				090	180
313	82 80 95		O-ring 89.5X3 FPM	1	1
327	83 97 97		Temperature sensor	1	1
328	665 86 00		Temperature sensor PT100, 2-LEADS 1500MM	1	1
329	718 81 00		Special washer	1	1
331	94 05 81		Insulating hose D=5 MM	*	*
332	665 86 00		Temperature sensor PT100, 2-LEADS 1500MM	1	1
335	83 53 77		Terminal clamp WPE 2.5 WS	1	1
336	83 42 36		End sleeve 0.75 MM <sup>2</sup> ; L=6 MM	2	2
337	94 03 34		Shrink hose ID=6.4 MM	*	*
338	82 40 61		Plain washer 24.5X35X2-A2-70	1	1
339	84 17 90		Seal sleeve (10)-12 MM FPM	1	1
339	84 17 92		Seal sleeve (14)-16 MM NBR	1	1
339	84 17 94		Seal sleeve (18)-20 MM NBR	1	1
339	84 17 95		Seal sleeve (20)-22 MM NBR	1	1
340	678 58 12	(Ex)	Cable clip 10-(12) MM	1	1
340	678 58 16	(Ex)	Cable clip 14-(16) MM	1	1
340	678 58 20	(Ex)	Cable clip 18-(20) MM	1	1
340	678 58 22	(Ex)	Cable clip 20-(22) MM	1	1
341	633 11 01		Gland screw ISO G1 1/4"	1	1
341	633 11 01		Gland screw ISO G1 1/4"	2	2
341	633 11 04		Gland screw 1 1/2" NPT	1	1
341	633 11 04		Gland screw 1 1/2" NPT	2	2
350	823 05 00		Pump monitoring	1	1
351	82 62 75		Transformer	1	1
352	83 45 59		Cable tie 200X2.4 PA 6/6-55+105	1	1
353	83 45 59		Cable tie 200X2.4 PA 6/6-55+105	1	1
354	83 43 60		Cable lug UL/CSA 0.50-1.65 MM <sup>2</sup> M4	1	1
355	718 81 00		Special washer	1	1
800	82 96 98		O-ring kit	1	1
800	82 96 99		O-ring kit	1	1
808	769 31 00		N-pump kit CURVE: 610 "N-LT"	1	1
808	769 31 02		N-pump kit CURVE: 614 "N-LT"	1	1
808	769 31 05		N-pump kit CURVE: 617 "N-LT"	1	1
808	769 31 08		N-pump kit CURVE: 431 "N-MT"	1	1
808	769 31 10		N-pump kit CURVE: 433 "N-MT"	1	1
808	769 31 13		N-pump kit CURVE: 640 "N-MT"	1	1
808	769 31 15		N-pump kit CURVE: 642 "N-MT"	1	1
808	769 31 18		N-pump kit CURVE: 452 "N-HT"	1	1
808	769 31 20		N-pump kit CURVE: 456 "N-HT"	1	1
808	769 31 22		N-pump kit CURVE: 460 "N-HT"	1	1

Pos. No	Part. No	Type	Denomination	Qty/Version	
				090	180
808	769 31 24		N-pump kit CURVE: 465 "N-HT"	1	1
808	769 31 26		N-pump kit CURVE: 467 "N-HT"	1	1
808	769 31 44		N-pump kit CURVE: 431 "N-MT"	1	1
808	769 31 46		N-pump kit CURVE: 433 "N-MT"	1	1
808	769 31 49		N-pump kit CURVE: 640 "N-MT"	1	1
808	769 31 51		N-pump kit CURVE: 642 "N-MT"	1	1
808	769 31 54		N-pump kit CURVE: 452 "N-HT"	1	1
808	769 31 56		N-pump kit CURVE: 456 "N-HT"	1	1
808	769 31 58		N-pump kit CURVE: 460 "N-HT"	1	1
808	769 31 60		N-pump kit CURVE: 465 "N-HT"	1	1
808	769 31 62		N-pump kit CURVE: 467 "N-HT"	1	1
808	769 31 65		N-pump kit CURVE: 270 "N-SH"	1	1
808	769 31 66		N-pump kit CURVE: 271 "N-SH"	1	1
808	769 31 67		N-pump kit CURVE: 273 "N-SH"	1	1
808	769 31 68		N-pump kit CURVE: 274 "N-SH"	1	1
808	769 31 69		N-pump kit CURVE: 275 "N-SH"	1	1
808	769 31 01		N-pump kit CURVE:612		1
808	769 31 03		N-pump kit CURVE:615		1
808	769 31 04		N-pump kit CURVE:616		1
808	769 31 06		N-pump kit CURVE:618		1
808	769 31 07		N-pump kit CURVE:619		1
808	769 31 09		N-pump kit CURVE:432		1
808	769 31 11		N-pump kit CURVE:434		1
808	769 31 12		N-pump kit CURVE:435		1
808	769 31 14		N-pump kit CURVE:641		1
808	769 31 16		N-pump kit CURVE:641		1
808	769 31 17		N-pump kit CURVE:450		1
808	769 31 19		N-pump kit CURVE:454		1
808	769 31 21		N-pump kit CURVE:458		1
808	769 31 23		N-pump kit CURVE:462		1
808	769 31 25		N-pump kit CURVE:466		1
808	769 31 27		N-pump kit CURVE:468		1
808	769 31 28		N-pump kit CURVE:469		1
808	769 31 45		N-pump kit CURVE:432		1
808	769 31 47		N-pump kit CURVE:434		1
808	769 31 48		N-pump kit CURVE:435		1
808	769 31 50		N-pump kit CURVE:641		1
808	769 31 52		N-pump kit CURVE:643		1
808	769 31 53		N-pump kit CURVE: 450		1
808	769 31 55		N-pump kit CURVE: 454		1
808	769 31 57		N-pump kit CURVE: 458		1
808	769 31 59		N-pump kit CURVE: 462		1
808	769 31 61		N-pump kit CURVE: 466		1
808	769 31 63		N-pump kit CURVE: 468		1

Pos. No	Part. No	Type	Denomination	Qty/Version	
				090	180
808	769 31 64		N-pump kit CURVE: 469		1
808	769 31 70		N-pump kit CURVE: 276		1
900	657 17 03		Basic repair kit	1	1
900	657 17 04		Basic repair kit	1	1
901	90 20 76		Monopropylene glycol	*	*
912	82 76 85		O-ring 17X3 NBR	3	3
912	82 79 15		O-ring 17X3 FPM	3	3



**ООО «Бауманс Груп» - официальный партнер фирмы Flygt в России.**

**Тел: +7 495 121 49 50**

**Эл. почта: [info@baumgroup.ru](mailto:info@baumgroup.ru)**

**Сайт: [www.baumgroup.ru](http://www.baumgroup.ru)**